

OPERATION MANUAL

SOTO-Y8 Air Purifier



Before operating the system, please read this manual thoroughly and retain it for future reference.

In full compliance with “General Hygienic Requirements for Air Disinfecting Machine” and registered as disinfection device in China

SOTO
Top-Grade Air Purifier



If you have the opportunity to experience SOTO air purifiers, please remember that they are designed with our dreams to meet your expectations...



Contents

Consumer Limited Warranty	04
Safety Precautions	05
How It Works	06
Features and Specifications	07
Part Name	08
Installation	09
Operation	10-12
Care and Maintenance	13-14
Troubleshooting	15

Consumer Limited Warranty

Congratulations on your investment

SOTO gives you the following limited warranty for this product only if it was originally purchased from SOTO or from an authorized dealer.

SOTO warrants that this product is free, under normal use and maintenance, from any defects in material and workmanship. If any such defects should be found in this product within the applicable warranty period. SOTO shall, at its option, repair or replace the product as specified herein.

SOTO will repair or replace, free of charge, to the original purchaser, any part that is found to be defective in material or workmanship within one (1) year of the date of purchase. This limited warranty does not cover the placement of expendable or consumable parts such as filters or UV lamps, and other parts subject to normal wear unless they are defective in material or workmanship.



This warranty shall not apply if:

1. Any defects caused or repairs required because of abusive operation, negligence, accident, improper installation or inappropriate use as outlined in the operation manual.
2. Any product tampered with modified, adjusted or repaired by any party other than SOTO.
3. Damaged caused or repairs because of the use with items not specified or approved by SOTO.
4. Any damage caused by external or environmental conditions (such as a fire or an earthquake), including but not limited to the use of voltage other than indicated on the product.
5. The content on the warranty card is inconsistent with the product, or there is no valid evidence to prove that the defective product is provided by SOTO.

Safety Precautions

To reduce the risk of electrical shock, fire or injury to person(s) read the following:



Running Environment Cautions

- Use only a 220-240 volt outlet with grounding wire receptacle.
- Do not use the unit in an enclosed space where oxygen, flammable, explosive or toxic vapors are given off by oil base paint, paint thinner, some moth proofing substances. It may cause explosion or fire.
- The product cannot be used in high-temperature, wet or watery places. Best working condition is 0-40°C and relative humidity of < 75%.



Unit Operation

- Do not operate the unit without filters. Make sure remove plastic packaging from the filters before operation.
- Do not use the unit if the power cord or plug is damaged or the connection to the wall outlet is loose.
- When removing the power plug, always hold the plug and never pull by the cord.
- Do not handle plug or appliance with wet hands. Electrical shock or fire from short circuit may occur.
- To avoid causing fire do not attempt to disassemble the unit - only certified technicians should do this.
- Stop the unit and unplug the power when maintenance.
- Do not insert fingers or foreign objects into the intake or air outlet.
- Keep hair, loose clothing, fingers and all parts of body away from openings and moving parts.
- Do not use the unit near or on hot objects, such as range or where it may be exposed to steam.
- Never look directly at UV lamps. Direct exposure to germicidal light can cause temporary or chronic damage to your eyesight, or even blindness.
- Do not wipe the outside, inside or any parts of the unit with flammable substances, it may cause fire!
- Do not wash or reuse the HEPA filter and Activated carbon filter.
- Photo catalytic is permanent, never needs replacing. When there is dust on it, clean the dust off using a vacuum cleaner dusting brush. Do not wash it in water.

How It Works

When the DC fan motor is running, the indoor air will be drawn through the bottom of the unit. The air will then pass through the HEPA filter, the Activated carbon filter and the UV-C+ Photo catalytic Nano-TiO₂ chamber. The purified air is then released through the outlet on the top of the unit. The Negative ion generators near the air outlet release revitalizing negative ions into the air to refresh the air.

Six Stages Purification

1. The nylon net on the outside of the HEPA filter traps large dust particles.
2. The high efficiency HEPA filter removes microscopic particles in the air.
3. The activated carbon filter will absorb odors and gases.
4. The UV lamp kill bacteria and viral microorganisms such as influenza, TB and Legionnaire's Disease as well as other harmful contaminants.
5. When UV light hits the photo catalytic filter, it creates e⁻ and h⁺, which have an excellent effect in the decomposition of odors.
6. The unit also generates negative ions that freshens the room air.

Sterilization Factor

1. The UV radiation destroys the DNA structure of bacteria and kills pathogenic microorganisms.
2. The UV ray wavelength is 254nm, and the average intensity of UV ray irradiation is 24μW/cm² at a position 1m below the UV lamp.

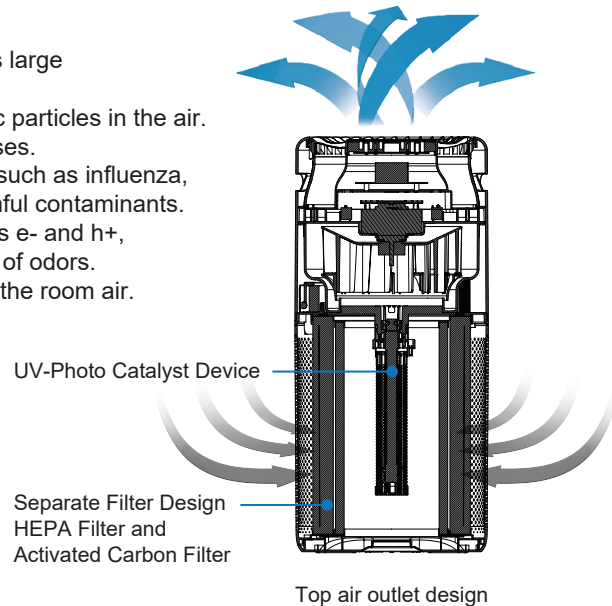

Features and Specifications

Features

The unit has a nylon net (traps large dust particles), HEPA filter (removes particles), activated carbon filter (absorbs odors and gases), UV-C+ lamp + Photo catalytic Nano-TiO₂ (killing airborne pathogen) and Negative ion generators (revitalize and refresh the air).

1. The odor and particle sensor can let the unit automatically select the appropriate fan speed depending on the air quality detected.
2. The unit can be operated completely with the wave of your hand, making it suitable in medical settings to avoid cross contamination.
3. The unit is also equipped with a safety interlock switch that will turn the power off if the bottom plate is opened.
4. The indicator lights tell you when to replace the HEPA filter, Activated carbon filter or the UV lamp.

Product Name	Air Purifier
Model	SOTO-Y8
Power Requirement	220V, 50Hz
Rated Power	56W
Negative Ion	2x3x10 ⁶ /cm ³
UV Lamp	10W
Dimensions	Φ29.5cm x H63.5cm
Weight	7.5kg

Part Name

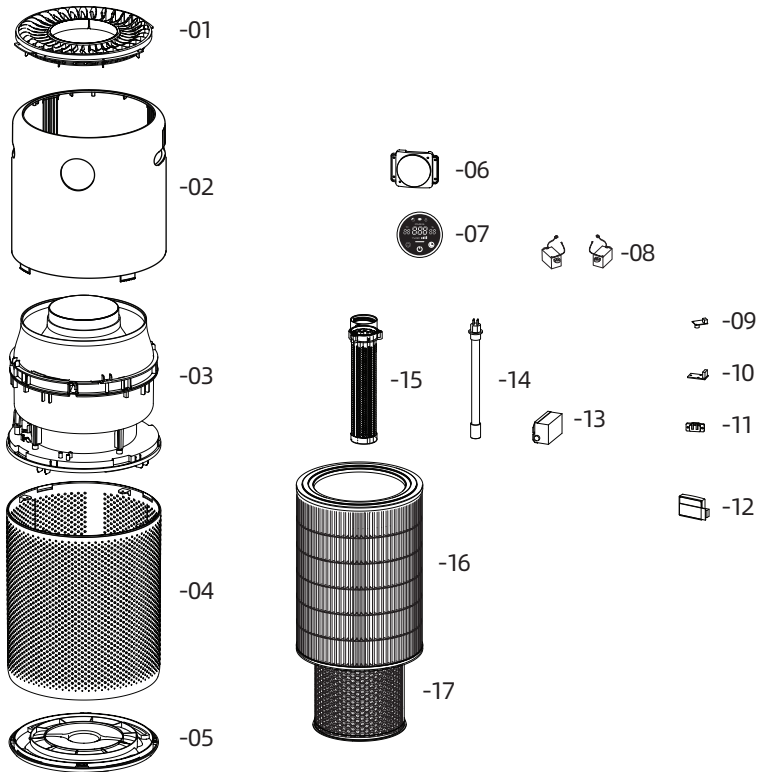

- 01- Air outlet
- 02- Upper shell
- 03- Fan unit
- 04- Lower shell
- 05- Bottom plate
- 06- Display panel
- 07- LED screen
- 08- Neg. ion
- 09- Odor sensor
- 10- TEMP/RH sensor
- 11- Power socket
- 12- Laser particle sensor
- 13- Ballast
- 14- UV lamp
- 15- Photo catalyst
- 16- HEPA filter
- 17- Activated carbon filter

Installation

1. Power supply condition: Use only a 220-volt outlet with grounding wire receptacle.
2. Environmental conditions: Temperature 0°C~40°C; Relative humidity <75%.
3. The unit should be installed in an indoor area with less personnel activities, and the unit should be set up against the wall.
4. This product is suitable for indoor air disinfection in human environment. It is strictly prohibited to use in flammable, explosive and other gas environment.

Before Operation

1. Turn unit upside down - put towel or any soft pad on the ground to avoid damage to the unit when you turn it upside down.
2. Open unit from the bottom - Turn counterclockwise to open bottom.
3. Take out the HEPA filter and the activated carbon filter to remove the plastic cover.
4. Put the HEPA filter and activated carbon filter back into unit. Align the redcross mark on the bottom plate with the same mark on the unit, turn the bottome plate clockwise to lock.



Caution

Prior to using unit for the first time, you must remove the plastic bag from the HEPA and activated carbon filter inside the unit.

Operation 1

Hand Gesture Operation

Plug the power cord in, the inner circle will turn blue, indicating the air purifier is in standby mode. Use your hand to wave over the sensor, this waving motion turns the unit on & off, and can also adjust the fan speed.

Wave	Circles on the sensor panel	Speed
1 st time	Blue circle will turn white	L
2 nd time	Second circle will light up	M
3 rd time	Third circle will light up	H
4 th time	All the circles light up white	Turbo
5 th time	“AUTO” indicator will light up	Auto
6 th time	Inner circle turns back to blue	Standby



Smart Auto Mode

The unit will adjust speeds accordingly based on what pollution the sensors pick up in the air. It also automatically turns off when $PM2.5 \leq 15\mu g/m^3$ and turns on when $PM2.5 \geq 25\mu g/m^3$.

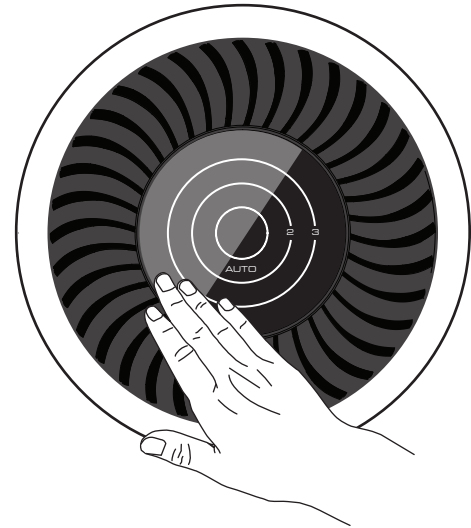

LOCK/ UNLOCK

Hover & hold your hand over the sensor for 2 seconds and this will lock the unit at the desired speed. This will prevent accidental or unwanted speed changes. To unlock this feature, hover & hold your hand over the sensor again for 2 seconds.

Operation 2

Button Operation/ Display Panel



Control Display Panel

NOTE

If the unit is not operated for one minute, the UV lamp button and NIGHT button light will go off except the POWER button, entering the screensaver mode.

1 POWER Button

- When the power cord in, the display panel shows the indoor PM2.5 concentration ($\mu\text{g}/\text{m}^3$), temperature and humidity.
- Press the button, turns the unit On and Off.
- Hold the button for 3 seconds to reset the filters indicator light.

2 UV LAMP Button: When the button is pressed, it will turn off the UV lamps, pressing again will turn on the UV light.

3 NIGHT Button: When pressed, all the indicator lights on the display panel will go out.

4 TIMER Indicator Light: When the operation time is set with remote control the indicator light turns on.

5 LOCK Indicator Light: When the unit is locked the indicator light is on (See page10).

6 Pollutant Level Display

The different colors indicate the air quality:

Blue=Good, Orange=Unhealthy, Red=Hazardous

Indicator Color	PM2.5	TVOC Level	Auto Speed
Blue	$\leq 75 \mu\text{g}/\text{m}^3$	■ ~ ■■	L
Orange	$76 \sim 150 \mu\text{g}/\text{m}^3$	■■■ ~ ■■■■	M
Red	$> 150 \mu\text{g}/\text{m}^3$		H

Operation 3

Remote Control Operation

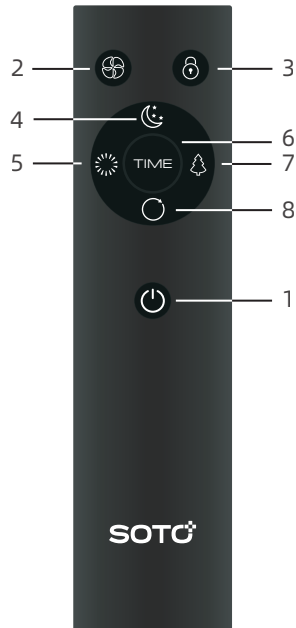

RF Remote Control



Before using the RF remote control

1. As soon as the unit is plugged in, press and hold the POWER button on the remote control for 5 seconds.
2. The indicator light will start flashing and this means the configuration is successful. The unit can now be operated with the remote control.

1 POWER Button: The unit will start operating when the POWER button is pressed. Pressing the button again will stop operation.

2 SPEED Button: The fan speed can be switched among L- M- H- Turbo- AUTO settings.

3 LOCK Button: When pressed, all the operation will lock at the desired speed except the NIGHT button.

4 NIGHT Button: When pressed, all the indicator lights on the display panel will go out.

5 UV LAMP Button: Turns UV lights on and off.

6 TIMER Button: The set time switches every time the button is pressed as shown below: 1h - 2h - 4h - C2 (Cycle mode) - Cancel.

7 NEG. ION Button: Turns negative ions on and off.

8 RESET Button: Pressing the reset button 3 times will reset the replacement indicator lights.

Care and Maintenance 1

To maintain optimum performance of this air purifier, the HEPA filter, the Activated carbon filter and the UV lamp need to be replaced when the indicator lights are flashing.

When maintenance on the unit, be sure to unplug the power cord, and never handle the plug with wet hands. If so, electrical shock and bodily injury may occur as a result.

Main unit

Wipe with a dry, soft cloth for stubborn stains or dirt. Do not use volatile fluids, Benzene, paint thinner, polishing powder, this may damage the surface.

Do not use detergents, detergent ingredients may damage the unit. Keep the unit away from water.

Replacing the HEPA filter

When the 3rd circle on the sensor plate flashes, the HEPA filter needs to be replaced.

1. Stop the operation and unplug the unit.
2. Open the bottom plate, take out the used HEPA filter and replace with a new one.
3. After replacing the HEPA filter, hold the POWER button to reset the time for the HEPA filter.

The 3rd circle flashes, replace the HEPA filter.

The 2nd circle flashes, replace the activated carbon filter.

The inner circle flashes, replace the UV lamp.

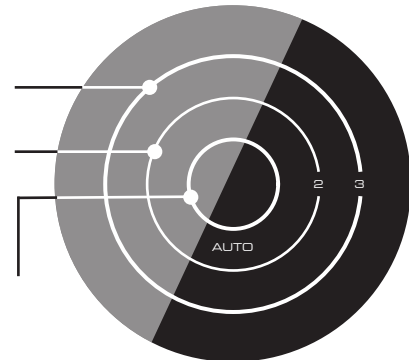

Schematic diagram of sensor plate panel on top of the unit. After replacing the filters and UV lamp, hold the POWER button to reset the indicator light.

Care and Maintenance 2

Replacing the Activated Carbon Filter

When the 2nd circle on the sensor plate flashes, the activated carbon filter needs to be replaced (See page13).

1. Stop the operation and unplug the unit.
2. Open the bottom plate, take out the used activated carbon filter and replace with a new one.
3. Operate the unit, press the POWER button for 3 seconds to reset the life time.

Replacing the UV Lamp

When the inner circle on the sensor plate flashes, the UV lamp needs to be replaced (See page13).

1. Stop the operation and unplug the unit.
2. Open the bottom plate, take out all filters. Replace UV lamp, as shown below:

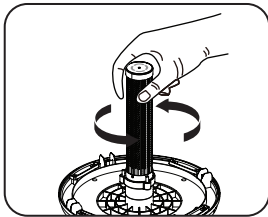

1. Take out all filters, unscrew the Photo catalyst device by turning it counterclockwise.

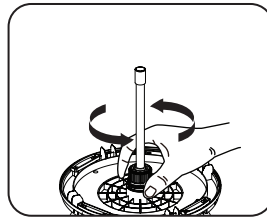

2. Unscrew the UV lamp holder by turning it counterclockwise.

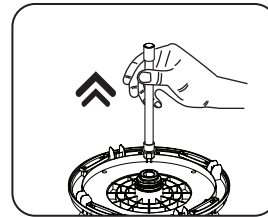

3. Take out the UV lamp upward, replace the new UV lamp

3. Operate the unit, press the POWER button for 3 seconds to reset the indicator light.

Troubleshooting

Service problems that appear to be major can often be solved easily. You can be your own troubleshooter by reviewing the following guide. All other servicing should be done by a SOTO authorized service center.

Case	What to check	Measure
The unit does not operate	Power failure? Power plug disconnected? Bottom plate or interlock switch failure?	Check other electrical appliances. Make sure plug is fully inserted. The unit does not operate when the bottom plate is detached. Install properly. Check interlock switch.
When functions do not work properly	There is too much dust on the HEPA filter or Activated carbon filter?	Replace the HEPA filter or the Activated carbon filter.



400-626-8883



customerservice@soto.com.cn

SOTO Air Purification North America

Add: D3-1105 Crestlawn Dr, Mississauga, ON, Canada

Tel: 289-643-5222

E-mail: info@sotonorthamerica.com

Web: <https://www.sotonorthamerica.com>

